

Exercising Fasting or Fed to Enhance Fat Loss? Influence of Food Intake on Respiratory Ratio and Excess Postexercise Oxygen Consumption After a Bout of Endurance Training

Antonio Paoli, Giuseppe Marcolin, Fabio Zonin, Marco Neri,
Andrea Sivieri, and Quirico F. Pacelli

Exercise and nutrition are often used in combination to lose body fat and reduce weight. In this respect, exercise programs are as important as correct nutrition. Several issues are still controversial in this field, and among them there are contrasting reports on whether training in a fasting condition can enhance weight loss by stimulating lipolytic activity. The authors' purpose was to verify differences in fat metabolism during training in fasting or feeding conditions. They compared the effect on oxygen consumption (VO_2) and substrate utilization, estimated by the respiratory-exchange ratio (RER), in 8 healthy young men who performed the same moderate-intensity training session (36 min of cardiovascular training on treadmill at 65% maximum heart rate) in the morning in 2 tests in random sequence: FST test (fasting condition) without any food intake or FED test (feeding condition) after breakfast. In both cases, the same total amount and quality of food was assumed in the 24 hr after the training session. The breakfast, per se, increased both VO_2 and RER significantly (4.21 vs. 3.74 and 0.96 vs. 0.84, respectively). Twelve hours after the training session, VO_2 was still higher in the FED test, whereas RER was significantly lower in the FED test, indicating greater lipid utilization. The difference was still significant 24 hr after exercise. The authors conclude that when moderate endurance exercise is done to lose body fat, fasting before exercise does not enhance lipid utilization; rather, physical activity after a light meal is advisable.

Keywords: breakfast, oxygen consumption, fasting condition, fed condition, fat loss

Physical activity is important for physical health, emotional well-being, and achieving a healthy weight. It has become increasingly clear that a person's health and well-being are improved by physical activity, as well as by a well-balanced diet (Centers for Disease Control and Prevention & National Center for Chronic Disease and Health Promotion, 1996). Both physical activity and diet stimulate processes that, over time, can reshape the morphologic composition and biochemical function of the body. Physical activity and diet are interrelated—optimal adaptation to the stress of exercise training requires a diet that does not lack any nutrient (Coyle, 2000). Moreover, physical exercise combined with dietary change improves weight loss (Kirkwood, Aldujaili, & Drummond, 2007; Shaw, Gennat, O'Rourke, & Del Mar, 2006), whereas the correlation between different kinds of diet and performance or between muscle hypertrophy and fat loss remains more controversial (Manninen, 2006; Pitsiladis & Maughan, 1999; Wolfe, 2000).

Some studies have examined the effects of preexercise carbohydrate feeding of different glycemic indexes and shown a positive effect on physiological parameters, with the low-glycemic-index food resulting in favorable substrate levels during exercise (Coggan & Coyle, 1987, 1989; Coyle et al., 1983; Paoli, Bargossi, Bianco, & Palma, 2008). On the other hand, the ability to sustain prolonged aerobic exercise is determined to a large extent by carbohydrate availability. Maintaining euglycemia and carbohydrate oxidation late in exercise can delay fatigue, which implies that carbohydrate intake before or during exercise may be a key to prolonging the duration of aerobic exercise (Maughan et al., 1997; Paoli et al., 2008). However, data on metabolic and exercise performance in relation to preexercise dietary carbohydrate intake are still controversial (Paoli et al., 2008). Previous studies have shown a decrease (Diboll, Boone, & Lindsey, 1999), no effect (Hargreaves, Costill, Fink, King, & Fielding, 1987), or an increase (Kirwan, O'Gorman, & Evans 1998; Sherman, Peden, & Wright, 1991) in glycogen utilization when carbohydrates are ingested 30–60 min before initiating aerobic exercise. Data on exercise performance after preexercise carbohydrate meals are equally unclear. Decreased (Thomas, Brotherhood, & Brand, 1991), unchanged (Hargreaves et al., 1987), and enhanced (Wright, Sherman, & Dernbach, 1991) exercise performance after preexercise

Paoli, Marcolin, and Pacelli are with the Dept. of Human Anatomy and Physiology, and Paoli and Sivieri, the School of Human Movement Sciences, University of Padua, Italy. Zonin and Neri are with the Italian Fitness Federation and the Italian Association of Fitness and Medicine, Ravenna, Italy.

carbohydrate meals have been reported, and there are few and contradictory results on correlations between meals and lipolytic mechanisms induced by exercise. As far as exercise and weight control, the correlation between energy expenditure during exercise and energy intake with feeding represents the most important determinant of the total caloric balance. In recent years, however, attention has also been focused on the concept that physical exercise induces excess postexercise oxygen consumption (EPOC; Børsheim & Bahr, 2003; LaForgia, Withers, & Gore, 2006). EPOC is a determinant of consumption in the hours after exercise and is, thus, responsible for greater energy expenditure (Maehlum, Grandmontagne, Newsholme, & Sejersted, 1986).

Some studies (Bergman & Brooks, 1999; Lyons et al., 2007; Short & Sedlock, 1997) have suggested that EPOC may have a greater role in weight control than previously recognized (Sedlock, Fissinger, & Melby, 1989). Long-lasting elevations of metabolism after exercise have been described (Bergman & Brooks, 1999; Lyons et al., 2007; Short & Sedlock, 1997), and low- and high-intensity exercise have been reported to have proportional effects on postexercise energy expenditure and substrate oxidation (Bergman & Brooks, 1999). It is evident how this is important for exercise programs for body-weight control, because correct nutrition is important. There are, however, very few studies on the combined effect of the two variables (exercise and nutrition) on EPOC (Bergman & Brooks, 1999). In books and popular magazines we may often read tips on how to enhance weight loss by training fasting. These recommendations are based on considerations such as the fact that in morning fasting, cortisol (lipolytic hormone) levels are higher and this should increase mobilization of fat. In addition, in morning fasting after night fasting, glycogen stores are very low, and this may further facilitate lipolytic processes (Binzen, Swan, & Manore, 2001; Koivisto et al., 1985). In contrast with this view, it is well known that the proportion of fat oxidized during the execution of exercise is negligible except in case of long-duration exercise beyond the capability of sedentary subjects who attend fitness centers to lose weight (Arnos, Sowash, & Andres, 1997). It becomes important, therefore, to investigate the impact of a training session in fasting conditions or after a meal on substrate consumption, by analyzing respiratory-exchange ratio (RER) and oxygen consumption. In particular, the unique aim of this study was to assess whether there were significant modifications induced by a typical fitness-training session (36 min of cardiovascular training on treadmill at 65% HR_{max}) performed in the morning without any food intake or after breakfast.

Materials and Methods

The participants were 8 trained men, age 27 ± 6 years, height 179.6 ± 6.7 cm, weight 91.3 ± 10.8 kg, with a resting heart rate (HR_{rest}) of 66.3 ± 10.2 beats/min and a 65% heart-rate reserve (HR_{res}) of 148.4 ± 5.7 beats/min. HR_{res} was calculated according to the Karvonen formula, originally proposed by Karvonen, Kentala and Mustala (1957):

$$HR_{res} = [(HR_{max} - HR_{rest}) \times 0.65] + HR_{rest}$$

where HR_{max} = maximal heart rate, calculated as $220 - \text{age}$.

All participants provided written informed consent on entering the study, which was approved by the local institutional ethics committee. The experimental protocol covered 2 weeks. Each participant underwent two tests with an interval of 1 week between: One test was a fasting test (FST), and the other test was a fed test (FED). Participants randomly performed either the FST or FED first. In both tests, data were collected before an endurance-training session and 12 and 24 hr after the end of the session. In the FST the training session was performed without food consumption in the preceding 12 hr (but subjects had a normal breakfast after the exercise session), whereas in the FED the training session was performed after a normal breakfast. The physiological parameters measured were heart rate, VO_2 , and carbon dioxide production. The participants were monitored by a heart-rate monitor (Polar S810; Polar, Kempele, Finland) and a portable system for pulmonary gas-exchange analysis (K4b2, Cosmed-Srl, Rome, Italy).

The gas analysis was performed in the morning (6–8 a.m.) after an overnight fast or after breakfast, while the subjects were seated. In particular, VO_2 was measured (ml/min) and normalized to body weight ($ml \cdot kg^{-1} \cdot min^{-1}$), and the RER was determined. In each subject, data were collected for 40 min, and only the middle 10 min (from 16th to 25th minute) were considered to calculate the respiratory-gas parameters. After data recording, the participants performed 36 min of training on the treadmill at 65% of their HR_{res} (Karvonen et al., 1957). HR_{max} had been previously evaluated during a cardiological evaluation with maximal exercise electrocardiography. Maximal exercise was conducted via ramp test: After 3 min of baseline cycling at 20 W, work rate was increased by 1 W every 3 s (i.e., 20 W/min) until the participant was unable to continue despite encouragement. The participants cycled at a self-selected rate (70–90 rpm) that remained constant throughout the test (Poole, Wilkerson, & Jones, 2008). To verify that none of the subjects modified their diet during the intervention protocol (the day before and during the test day) an assessment of dietary intake was performed and analyzed using DietComp (Caldogno, Vicenza, Italy) software, which demonstrated a substantial similarity.

FST Condition

In the morning the anthropometric data and the pulmonary gas exchange of the participants were measured (FST_{basal}). After 40 min of complete rest the measurement was repeated to confirm the basal data (FST_0). Right after the second measurement the participants performed the cardiovascular training session, and at the end they had their usual breakfast. During the rest of the day, they consumed a standard lunch, afternoon snack, and dinner and breakfast the next morning. After 12 and 24 hr (FST_{12} and FST_{24}) from the end of the training session, gas-exchange analysis was repeated. A complete chart of the protocol is shown in Figure 1.

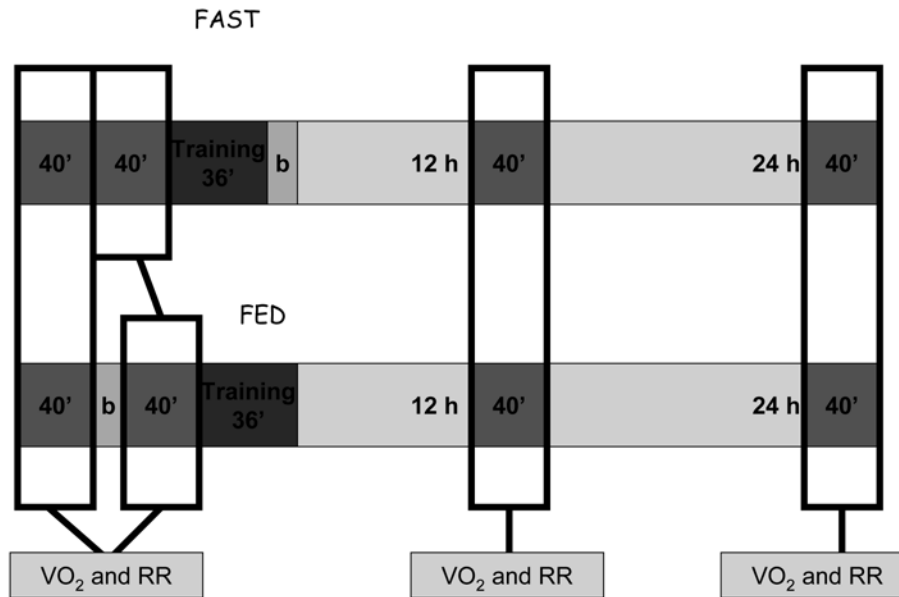

Figure 1 — Experimental design. b = breakfast; FAST = fasting protocol; FED = feeding protocol; VO_2 = oxygen consumption; RR = respiratory-exchange ratio.

FED Condition

In FED, the participants followed the same schedules as for FST. This time, however, they were not fasting but consumed a standard Mediterranean breakfast (25% protein, 22% carbohydrate, and 53% lipids) after the first basal measurement of gas exchange (FED_{basal}). The breakfast had a caloric contribution of 673 kcal. After the second gas-exchange measurement (FED_0), the participants performed the endurance training, then they followed the same standard alimentary regimen as in FST, and, 12 and 24 hr (FED_{12} and FED_{24}) after the end of the training session, gas-exchange analysis was repeated. A complete chart of the protocol is shown in Figure 1.

Statistical Analysis

Bland–Altman plots and comparison of the test–retest Cosmed measurements made in our laboratory confirmed previous data (Duffield, Dawson, Pinnington, & Wong, 2004) about good repeatability of measurement for RER and VO_2 ($ICC > .85$ and $> .9$, respectively; $p < .05$) of the K4b2 system.

Mean power for our measurement was calculated using GraphPad StatMate 2.00. With an alpha of 5%, corresponding to a 95% confidence interval, we had a mean power $>80\%$ with this sample size.

Data are expressed as means and standard errors. Data analysis was performed using the software package GraphPad Prism version 4.00 for Windows (GraphPad Software, San Diego, CA). A repeated-measures analysis of variance (ANOVA; Condition \times Time) within participants was conducted. In this kind of experimental design subjects serve as their own control (Schutz &

Gessaroli, 1987). Whenever significant differences in values occurred, multiple comparison tests (useful for determining where significant differences occur between pairs of groups) were performed using a post hoc Tukey–Kramer test, considered the most powerful method of all (pairwise comparisons). Alpha significance level was set at .05.

Results

In the basal condition, VO_2 and RER in the two experimental sessions were equivalent (VO_2 FST_{basal} 3.69 ± 0.21 vs. FED_{basal} 3.71 ± 0.24 ml $O_2 \cdot kg^{-1} \cdot min^{-1}$; RER FST_{basal} 0.84 ± 0.07 vs. FED_{basal} 0.84 ± 0.09). In contrast, significant differences were detectable between FST and FED sessions in all subsequent measurements except at t_0 in the FST condition. The values of VO_2 and RER before and after the training session are reported in Figures 2 and 3. Before the training session (i.e., after breakfast in FED), both VO_2 and RER showed significant differences, $p < .001$ (VO_2 FST_0 3.74 ± 0.26 vs. FED_0 4.21 ± 0.35 ml $O_2 \cdot kg^{-1} \cdot min^{-1}$; RER FST_0 0.84 ± 0.03 vs. FED_0 0.96 ± 0.06) because of food intake. Significant differences in VO_2 between FST and FED were also detectable at t_{12} , $p < .01$ (FST_{12} 4.12 ± 0.40 vs. FED_{12} 4.47 ± 0.40 ml $O_2 \cdot kg^{-1} \cdot min^{-1}$), and t_{24} , $p < .05$ (FST_{24} 3.94 ± 0.27 vs. FED_{24} 4.26 ± 0.44 ml $O_2 \cdot kg^{-1} \cdot min^{-1}$), with a higher VO_2 in the FED session than in the FST session (Figure 3). RER also showed significant differences—a lower RER was found both at t_{12} ($p < .05$, FST_{12} 0.79 ± 0.03 vs. FED_{12} 0.74 ± 0.03) and t_{24} ($p < .001$, FST_{24} 0.870 ± 0.02 vs. FED_{24} 0.78 ± 0.02) in FED than in FST (Figure 2). Comparison of VO_2 measurements at different times in each experimental

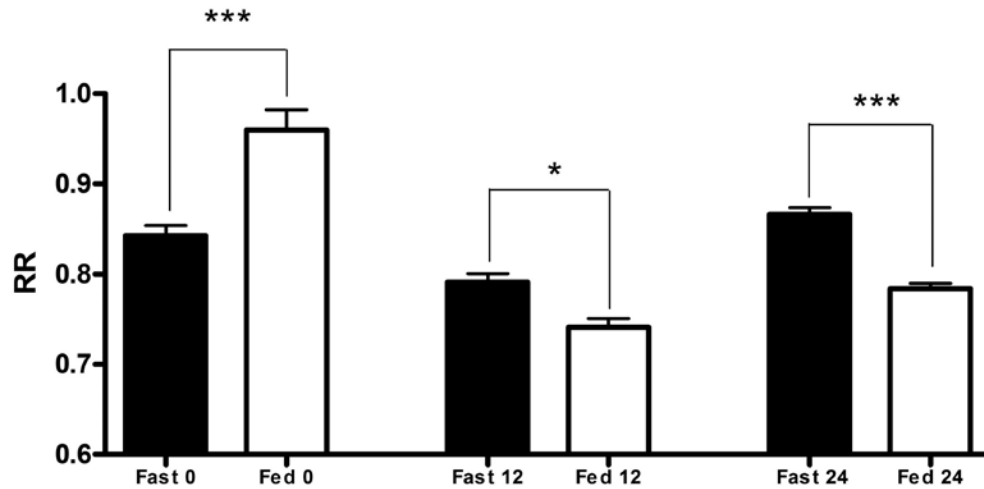

Figure 2 — Differences in respiratory-exchange ratio (RR) between the fasted (black columns) and fed (white columns) protocols before the exercise session and 12 and 24 hr after. * $p < .05$; *** $p < .001$. Comparison among different times for each condition based on repeated-measures ANOVA showed that fasting $t_0 > t_{12}$ ($p < .05$), $t_{24} > t_{12}$ ($p < .001$), t_0 vs. t_{24} n.s.; and fed $t_0 > t_{12}$ ($p < .001$), $t_0 > t_{24}$ ($p < .001$), t_{12} vs. t_{24} n.s.

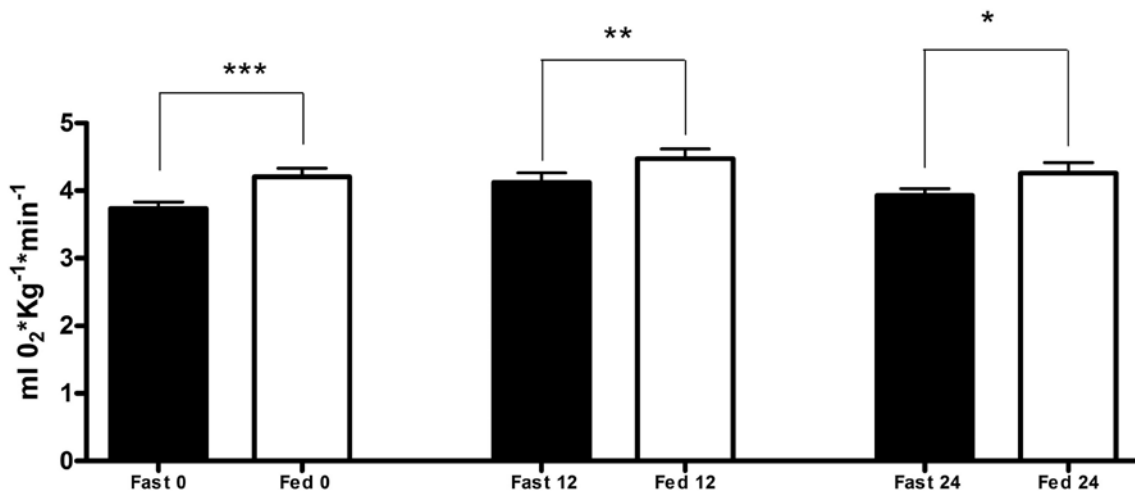

Figure 3 — Differences of oxygen consumption between the fasted (black columns) and fed (white columns) protocols before the exercise session and 12 and 24 hr after. * $p < .05$; ** $p < .01$; *** $p < .001$. Comparison among different times for each condition based on repeated-measures ANOVA showed that fasting $t_0 < t_{12}$ ($p < .01$), t_{24} vs. t_{12} n.s., t_0 vs. t_{24} n.s.; fed t_0 vs. t_{12} n.s., t_0 vs. t_{24} n.s., t_{12} vs. t_{24} n.s.

session revealed a significantly higher value at t_{12} than t_0 , without any other significant differences in FST; in FED there was no significant difference among different times. Finally, the comparison of RER values at different times in FED revealed significant differences, with the higher value at t_0 and the lower at t_{12} , whereas in FST the value at 12 hr was significantly lower than the other values.

There were no significant differences in VO_2 measured before training (t_0) and after 12 (t_{12}) and 24 (t_{24}) hr in either session (see Figure 3), suggesting that no EPOC was induced by the selected intensity of exercise, and the differences between sessions resulted from the initial modification induced by breakfast.

Discussion

The results of the comparison between the two protocols (training fasting and training feeding) showed that before the training session both VO_2 and RER were significantly higher FED after breakfast (also higher than in FED_{basal}), likely as a result of food intake. As expected, RER was increased by food intake, suggesting a shift of substrate utilization from lipids to carbohydrate. In addition the rate of VO_2 was significantly stimulated by the caloric consumption as previously demonstrated (Johnston, Day, & Swan, 2002; Keogh, Lau, Noakes, Bowen, & Clifton, 2007; Scott & Devore, 2005). It is interesting

that significant differences between the two conditions were also detectable many hours after the training session. The RER was lower both at 12 and 24 hr after the exercise session in the FED (breakfast before exercise) than in FST (breakfast after exercise). Thus, a prolonged effect on substrate utilization occurs with a shift toward lipids with feeding before exercise. In the same condition—feeding before exercise— VO_2 remained higher at both 12 and 24 hr, indicating an enhanced EPOC effect. Regarding the differences within each condition, the lack of difference before training (t_0) and after 12 (t_{12}) and 24 (t_{24}) hr in FED suggested that the differences in EPOC (at t_{12} and t_{24}) between FST and FED were caused by the greater initial increase in VO_2 induced by breakfast before training (FED₀ vs. FST₀). In other words, the differences between experimental conditions during the 24 hr in VO_2 were probably triggered by the first (FED₀) great increase resulting from breakfast before training, which allowed the EPOC to remain high. Comparing times within the FST condition, there was only a slight elevation in t_{12} with respect to t_0 .

Several studies have been carried out to identify factors that contribute to elevated EPOC and to describe the magnitude and duration of this event (Schuenke, Mikat, & McBride, 2002). Factors that increase postexercise VO_2 are important to enhance the loss of body-fat stores. The basic lifestyle that prevents conditions such as being overweight and obese is regular exercise that increases daily energy expenditure and fat oxidation. Some studies, however, have shown that physical activity combined with dietary changes improves weight loss (Kirkwood, Aldujaili, & Drummond, 2007; Shaw et al., 2006).

In regard to physical activity to lose body fat, a first important issue is the intensity of exercise. Generally speaking, the highest rates of fat oxidation are found at low to moderate exercise intensities (33–65% $\text{VO}_{2\text{max}}$; Bergman & Brooks, 1999). There is a progressive increase in the relative contribution of carbohydrate oxidation to energy expenditure and a corresponding decrease in the relative contribution of fat oxidation to energy expenditure. However, from low to moderate intensities of exercise, the absolute rate of fat oxidation increases and then declines as exercise becomes even more intense (Howley, Duncan, & Del Corral, 1997; Romijn, Coyle, Sidos-sis, Rosenblatt, & Wolfe, 2000; Thompson, Townsend, Boughey, Patterson, & Bassett, 1998).

A second important issue is whether fasting combined with training may increase lipid oxidation. Many studies have shown that there is a reduction in RER and thus increased lipid oxidation with training in fasting conditions (Broeder et al., 1991). The current results showed that lipid oxidation after exercise was greater in the session with breakfast before exercise than in fasting training.

A further interesting result of our study was that moderate endurance training (36 min at 65% HR_{res}) did not influence EPOC in the subsequent 12 and 24 hr. These data confirm those of previous studies (Melby, Scholl, Edwards, & Bullough, 1993; Phelain, Reinke, Harris, & Melby, 1997) that showed a positive correlation between

intensity of exercise and EPOC in the 24 hr after a training session. Thus, relatively low-intensity endurance training does not significantly influence EPOC in hours following. As confirmed by Schuenke et al. (2002), highly intense exercise is necessary to induce EPOC in the few subsequent hours. The comparison of FST and FED indicates that breakfast, per se, significantly increased VO_2 , and this increase could be maintained for hours because of exercise. These results are consistent with those on the influence of digestion on metabolism (Johnston et al., 2002; Keogh et al., 2007; Scott & Devore, 2005), but note that training after breakfast allows maintenance of a greater VO_2 than training in a fasting condition.

RER after breakfast increased (FED₀ 0.96 vs. FST₀ 0.84), which can be explained by an increase of carbohydrate utilization immediately after food consumption. On the other hand, RER decreased more during FED than during FST and, at t_{12} , RER was lower during FED than during FST (FED₁₂ 0.74 vs. FST₁₂ 0.79). The same was found at t_{24} (FED₂₄ 0.87 vs. FST₂₄ 0.78). This greater decrease after 12 and 24 hr in FED than in FST points to an improvement of fat utilization. The combination of higher VO_2 and reduced RER can be ascribed to a maintained increased protein synthesis after training and also to the reconstitution of glycogen (Fine & Feinman, 2004). Probably because of hormonal induction, breakfast leads to an elevation of these mechanisms (Fujita et al., 2007; Kumar, Atherton, Smith, & Rennie, 2009). Despite the extensive literature about the effect of exercise and diet (and combined effects of both) on EPOC and RER, to our knowledge no studies have been performed on the effects of typical lipolytic exercise used in fitness centers under fasting and fed conditions. The importance of this kind of approach is related to tips that we may often read in fitness books and popular magazines that suggest to train fasting to enhance fat loss. From a practical point of view, the results obtained in this study suggest that, over long periods, exercising after breakfast would be more effective than fasting training to lose weight through the increased metabolism and reduced RER in the hours after the training session. It would be worthwhile to study whether exercise of greater intensity would produce the same differences in relation to fasting and fed conditions. In any case, the current data suggest that it is better to avoid training in fasting conditions with moderate endurance training if fat loss is the target.

Acknowledgments

None of the authors have potential conflicts of interest. This work was supported by a grant from the Department of Human Anatomy and Physiology, University of Padua, Italy.

References

- Arnos, P.M., Sowash, J., & Andres, F.F. (1997). Fat oxidation at varied work intensities using different exercise modes. *Medicine and Science in Sports and Exercise*, 29(5), S199.

- Bergman, B.C., & Brooks, G.A. (1999). Respiratory gas-exchange ratios during graded exercise in fed and fasted trained and untrained men. *Journal of Applied Physiology (Bethesda, Md.)*, 86(2), 479–487.
- Binzen, C.A., Swan, P.D., & Manore, M.M. (2001). Postexercise oxygen consumption and substrate use after resistance exercise in women. *Medicine and Science in Sports and Exercise*, 33(6), 932–938.
- Børsheim, E., & Bahr, R. (2003). Effect of exercise intensity, duration and mode on post-exercise oxygen consumption. *Sports Medicine (Auckland, N.Z.)*, 33(14), 1037–1060.
- Broeder, C.E., Brenner, M., Hofman, Z., Pajmans, I.J., Thomas, E.L., & Wilmore, J.H. (1991). The metabolic consequences of low and moderate intensity exercise with or without feeding in lean and borderline obese males. *International Journal of Obesity*, 15(2), 95–104.
- Centers for Disease Control and Prevention & National Center for Chronic Disease and Health Promotion. (1996). *Physical activity and health: A report of the Surgeon General*. Washington, DC: U.S. Government Printing Office.
- Coggan, A.R., & Coyle, E.F. (1987). Reversal of fatigue during prolonged exercise by carbohydrate infusion or ingestion. *Journal of Applied Physiology (Bethesda, Md.)*, 63(6), 2388–2395.
- Coggan, A.R., & Coyle, E.F. (1989). Metabolism and performance following carbohydrate ingestion late in exercise. *Medicine and Science in Sports and Exercise*, 21(1), 59–65.
- Coyle, E.F. (2000). Physical activity as a metabolic stressor. *The American Journal of Clinical Nutrition*, 72(2), 512S–520S.
- Coyle, E.F., Hagberg, J.M., Hurley, B.F., Martin, W.H., Ehsani, A.A., & Holloszy, J.O. (1983). Carbohydrate feeding during prolonged strenuous exercise can delay fatigue. *Journal of Applied Physiology: Respiratory, Environmental and Exercise Physiology*, 55(1 Pt 1), 230–235.
- Diboll, D.C., Boone, W.T., & Lindsey, L.R. (1999). Cardiovascular and metabolic responses during 30 minutes of treadmill exercise shortly after consuming a small, high-carbohydrate meal. *International Journal of Sports Medicine*, 20(6), 384–389.
- Duffield, R., Dawson, B., Pinnington, H.C., & Wong, P. (2004). Accuracy and reliability of a Cosmed K4b2 portable gas analysis system. *Journal of Science and Medicine in Sport*, 7(1), 11–22.
- Fine, E.J., & Feinman, R.D. (2004). Thermodynamics of weight loss diets. *Nutrition & Metabolism*, 1, 15.
- Fujita, S., Dreyer, H.C., Drummond, M.J., Glynn, E.L., Cadenas, J.G., Yoshizawa, F., . . . Rasmussen, B.B. (2007). Nutrient signalling in the regulation of human muscle protein synthesis. *Journal of Physiology*, 15(582 Pt. 2), 813–823.
- Hargreaves, M., Costill, D.L., Fink, W.J., King, D.S., & Fielding, R.A. (1987). Effect of pre-exercise carbohydrate feedings on endurance cycling performance. *Medicine and Science in Sports and Exercise*, 19(1), 33–36.
- Howley, E.T., Duncan, G.E., & Del Corral, P. (1997). Optimum intensity for fat oxidation. *Medicine and Science in Sports and Exercise*, 29(5), S199.
- Johnston, C.S., Day, C.S., & Swan, P.D. (2002). Postprandial thermogenesis is increased 100% on a high-protein, low-fat diet versus a high-carbohydrate, low-fat diet in healthy, young women. *Journal of the American College of Nutrition*, 21(1), 55–61.
- Karvonen, M.J., Kentala, E., & Mustala, O. (1957). The effects of training on heart rate: A longitudinal study. *Annales Medicinae Experimentalis et Biologiae Fenniae*, 35(3), 307–315.
- Keogh, J.B., Lau, C.W., Noakes, M., Bowen, J., & Clifton, P.M. (2007). Effects of meals with high soluble fibre, high amylose barley variant on glucose, insulin, satiety and thermic effect of food in healthy lean women. *European Journal of Clinical Nutrition*, 61(5), 597–604.
- Kirkwood, L., Aldujaili, E., & Drummond, S. (2007). Effects of advice on dietary intake and/or physical activity on body composition, blood lipids and insulin resistance following a low-fat, sucrose-containing, high-carbohydrate, energy-restricted diet. *International Journal of Food Sciences and Nutrition*, 58(5), 383–397.
- Kirwan, J.P., O’Gorman, D., & Evans, W.J. (1998). A moderate glycemic meal before endurance exercise can enhance performance. *Journal of Applied Physiology (Bethesda, Md.)*, 84(1), 53–59.
- Koivisto, V.A., Harkonen, M., Karonen, S.L., Groop, P.H., Elovainio, R., Ferrannini, R., . . . Defronzo, R.A. (1985). Glycogen depletion during prolonged exercise: Influence of glucose, fructose, or placebo. *Journal of Applied Physiology (Bethesda, Md.)*, 58(3), 731–737.
- Kumar, V., Atherton, P., Smith, K., & Rennie, M.J. (2009). Human muscle protein synthesis and breakdown during and after exercise. *Journal of Applied Physiology (Bethesda, Md.)*, 106(6), 2026–2039.
- LaForgia, J., Withers, R.T., & Gore, C.J. (2006). Effects of exercise intensity and duration on the excess post-exercise oxygen consumption. *Journal of Sports Sciences*, 24(12), 1247–1264.
- Lyons, S., Richardson, M., Bishop, P., Smith, J., Heath, H., & Giesen, J. (2007). Excess post-exercise oxygen consumption in untrained men following exercise of equal energy expenditure: Comparisons of upper and lower body exercise. *Diabetes, Obesity & Metabolism*, 9(6), 889–894.
- Maehlum, S., Grandmontagne, M., Newsholme, E.A., & Sejersted, O.M. (1986). Magnitude and duration of excess postexercise oxygen consumption in healthy young subjects. *Metabolism: Clinical and Experimental*, 35(5), 425–429.
- Manninen, A.H. (2006). Hyperinsulinaemia, hyperaminoacidaemia and post exercise muscle anabolism: The search for the optimal recovery drink. *British Journal of Sports Medicine*, 40, 900–905.
- Maughan, R.J., Greenhaff, P.L., Leiper, J.B., Ball, D., Lambert, C.P., & Gleeson, M. (1997). Diet composition and the performance of high-intensity exercise. *Journal of Sports Sciences*, 15(3), 265–275.
- Melby, C., Scholl, C., Edwards, G., & Bullough, R. (1993). Effect of acute resistance exercise on postexercise energy expenditure and resting metabolic rate. *Journal of Applied Physiology (Bethesda, Md.)*, 75(4), 1847–1853.
- Paoli, A., Bargossi, A.M., Bianco, A., & Palma, A. (2008). Carbohydrate supplementation and sport: A review. *Rivista della Facoltà di Scienze Motorie dell’Università degli Studi di Palermo*, 1(2), 225–235.

- Phelain, J.F., Reinke, E., Harris, M.A., & Melby, C.L. (1997). Postexercise energy expenditure and substrate oxidation in young women resulting from exercise bouts of different intensity. *Journal of the American College of Nutrition*, 16(2), 140–146.
- Pitsiladis, Y.P., & Maughan, R.J. (1999). The effects of alterations in dietary carbohydrate intake on the performance of high-intensity exercise in trained individuals. *European Journal of Applied Physiology and Occupational Physiology*, 79(5), 433–442.
- Poole, D.C., Wilkerson, D.P., & Jones, A.M. (2008). Validity of criteria for establishing maximal O₂ uptake during ramp exercise tests. *European Journal of Applied Physiology*, 102(4), 403–410.
- Romijn, J.A., Coyle, E.F., Sidossis, L.S., Rosenblatt, J., & Wolfe, R.R. (2000). Substrate metabolism during different exercise intensities in endurance-trained women. *Journal of Applied Physiology (Bethesda, Md.)*, 88(5), 1707–1714.
- Schuenke, M.D., Mikat, R.P., & McBride, J.M. (2002). Effect of an acute period of resistance exercise on excess post-exercise oxygen consumption: Implications for body mass management. *European Journal of Applied Physiology*, 86(5), 411–417.
- Schutz, R.W., & Gessaroli, M.E. (1987). The analysis of repeated measures designs involving multiple dependent variables. *Research Quarterly for Exercise and Sport*, 58, 132–149.
- Scott, C.B., & Devore, R. (2005). Diet-induced thermogenesis: Variations among three isocaloric meal-replacement shakes. *Nutrition (Burbank, Los Angeles County, Calif.)*, 21(7-8), 874–877.
- Sedlock, D.A., Fissinger, J.A., & Melby, C.L. (1989). Effect of exercise intensity and duration on post-exercise energy expenditure. *Medicine and Science in Sports and Exercise*, 21(6), 662–666.
- Shaw, K., Gennat, H., O'Rourke, P., & Del Mar, C. (2006). Exercise for overweight or obesity. *Cochrane Database of Systematic Reviews*, 18(4), CD003817.
- Sherman, W.M., Peden, M.C., & Wright, D.A. (1991). Carbohydrate feedings 1 h before exercise improves cycling performance. *The American Journal of Clinical Nutrition*, 54, 866–870.
- Short, K.R., & Sedlock, D.A. (1997). Excess post-exercise oxygen consumption and recovery rate in trained and untrained subjects. *Journal of Applied Physiology (Bethesda, Md.)*, 83(1), 153–159.
- Thomas, D.E., Brotherhood, J.R., & Brand, J.C. (1991). Carbohydrate feeding before exercise: Effect of glycemic index. *International Journal of Sports Medicine*, 12, 180–186.
- Thompson, D.L., Townsend, K.M., Boughey, R., Patterson, K., & Bassett, D.R., Jr. (1998). Substrate use during and following moderate and low-intensity exercise: Implications for weight control. *European Journal of Applied Physiology and Occupational Physiology*, 78(1), 43–49.
- Wolfe, R.R. (2000). Protein supplements and exercise. *The American Journal of Clinical Nutrition*, 72(Suppl.), 551S–557S.
- Wright, D.A., Sherman, W.M., & Dernbach, A.R. (1991). Carbohydrate feedings before, during, or in combination improve cycling endurance performance. *Journal of Applied Physiology (Bethesda, Md.)*, 71(3), 1082–1088.

Copyright of International Journal of Sport Nutrition & Exercise Metabolism is the property of Human Kinetics Publishers, Inc. and its content may not be copied or emailed to multiple sites or posted to a listserv without the copyright holder's express written permission. However, users may print, download, or email articles for individual use.